



Disclaimers

EFINIX DOES NOT PROVIDE ANY WARRANTY OF ACCURACY, COMPLETENESS, MERCHANTABILITY, OR NONINFRINGEMENT OF THIRD-PARTY RIGHTS ON THIS DOCUMENT. THE INFORMATION IN THIS DOCUMENT IS “AS IS”; IN NO EVENT WILL EFINIX BE LIABLE FOR ANY EXEMPLARY, SPECIAL, CONSEQUENTIAL, INDIRECT, OR INCIDENTAL DAMAGES, INCLUDING ANY LOSS OF DATA, LOSS OF PROFITS, LOSS OF INFORMATION, LOSS OF LIFE OR BUSINESS INTERRUPTION, ARISING FROM YOUR USE OF THIS DOCUMENT.

EFINIX shall make changes to this document at any time without notification. EFINIX assumes no obligation to correct any errors contained in this document or to advise any user of this document of any correction if such be made. EFINIX advises its customers to obtain the latest FPGA schematic before ordering so that no conflict of information correctness arises afterward.

Ti375C529 Development Board REV A1

CONTENTS

PAGE 01	-	Table of Contents
PAGE 02	-	Block Diagram
PAGE 03	-	Power Input-1
PAGE 04	-	Power Input-2
PAGE 05	-	Power Input-3
PAGE 06	-	Power Input-4
PAGE 07	-	Power Input-5
PAGE 08	-	FPGA Power
PAGE 09	-	FPGA LPDDR4/4X
PAGE 10	-	PMOD & OSCILLATOR
PAGE 11	-	MIPI INTERFACE
PAGE 12	-	FPGA_BANKIO_1
PAGE 13	-	FPGA_FMC
PAGE 14	-	FPGA_BANKIO_2
PAGE 15	-	Ethernet
PAGE 16	-	JTAG & SPI Flash
PAGE 17	-	S.COMM, User IO

DOCUMENT VERSION HISTORY

VER	DATE	EDITOR	DESCRIPTION
Rev A1	12/06/2024	PE Team	Initial Release

Ti375C529 BLOCK DIAGRAM

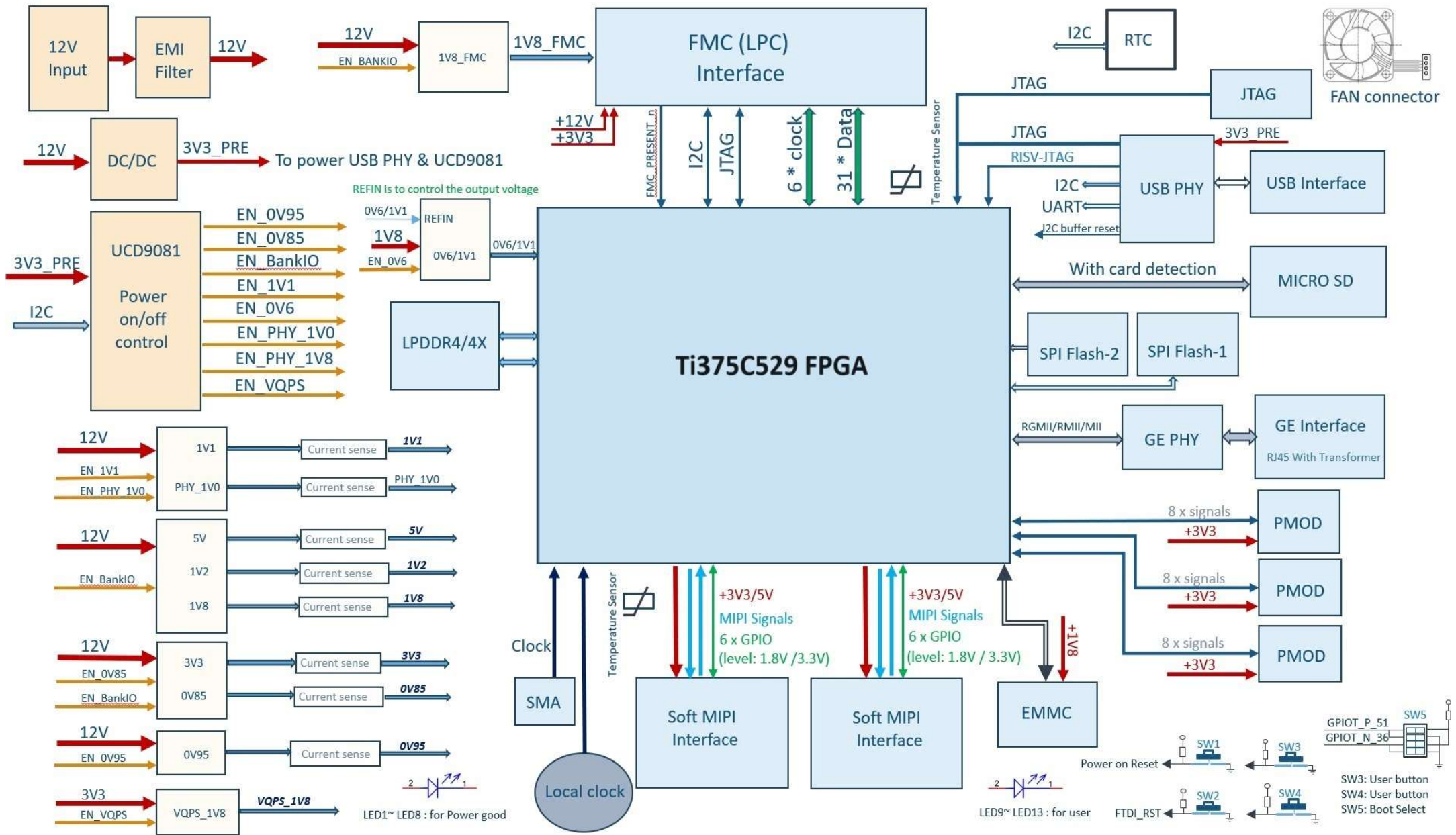

POWER INPUT 1

12V DC Input

0V95

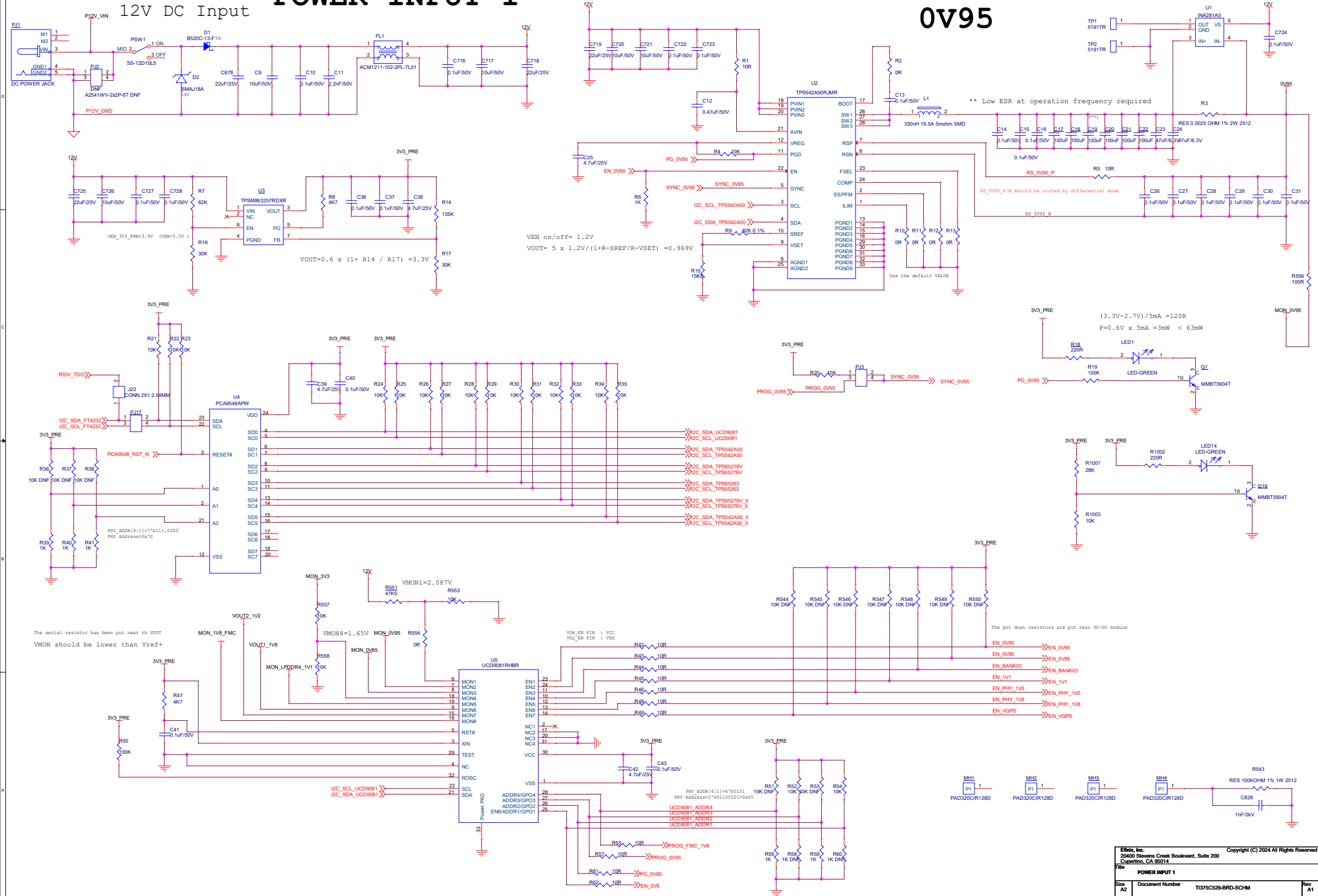

VEN on/off = 1.2V
 $V_{OUT} = 5 \times 1.2V / (1 + R-SREF/R-VSET) = 0.969V$

$(3.3V - 2.7V) / 5mA = 120R$
 $P = 0.6V \times 5mA = 3mW < 63mW$

The put down resistors are put near DC-DC module

The serial resistor has been put near the VOUT
 VMON should be lower than Vref+

POWER INPUT2

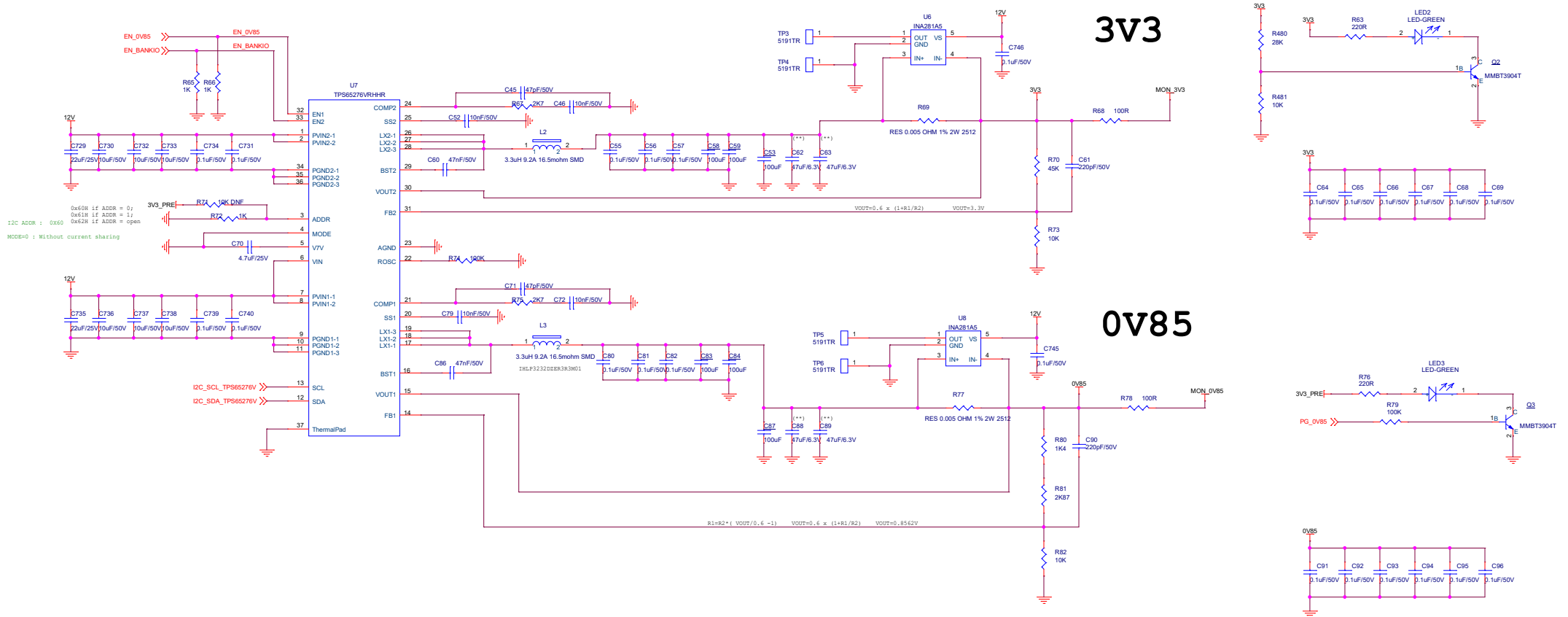

POWER INPUT 3

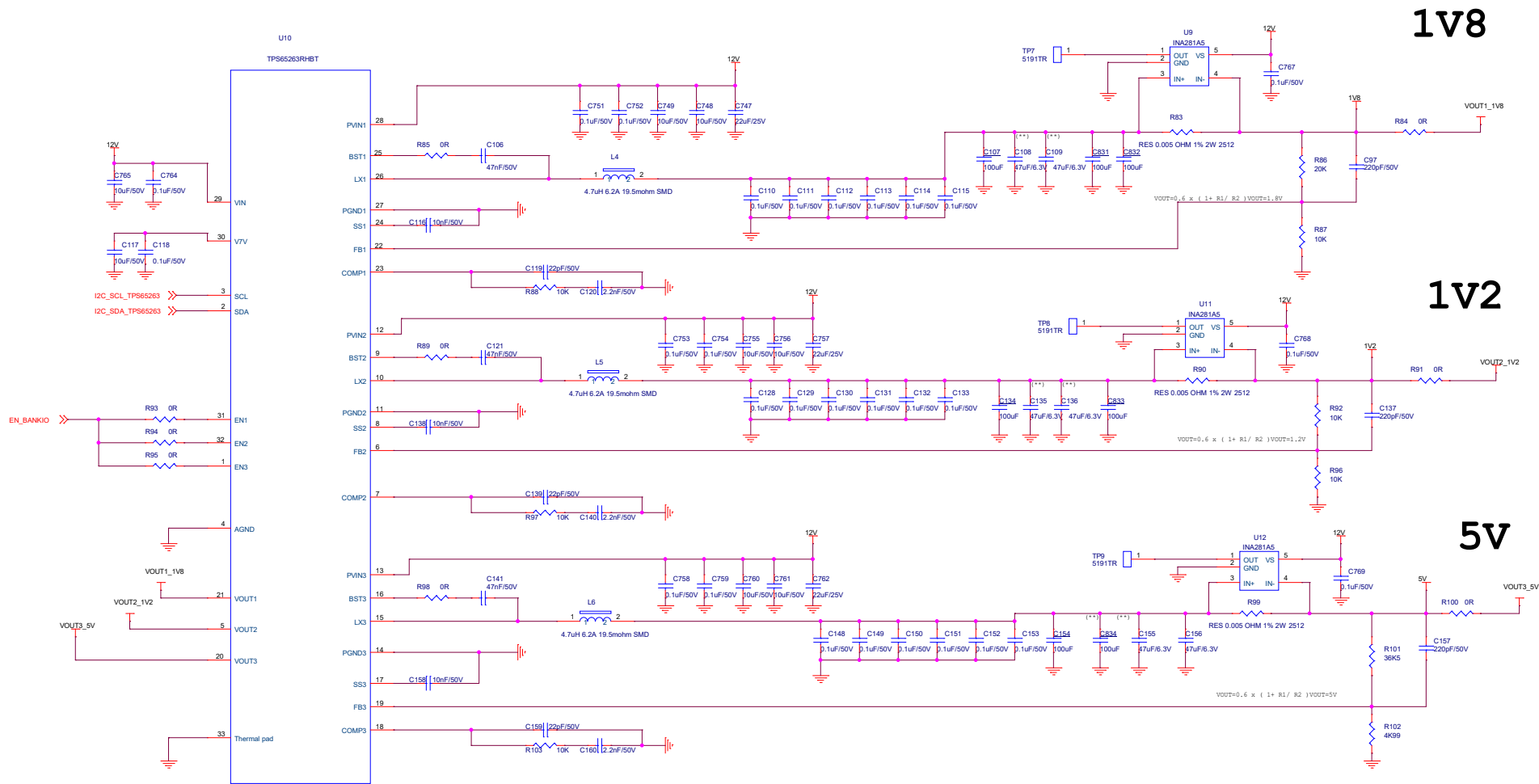

1V8

1V2

5V

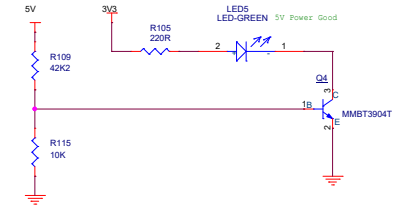
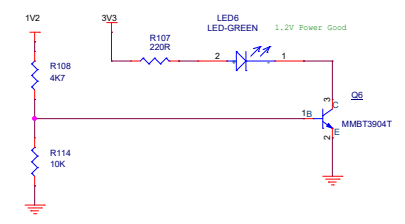
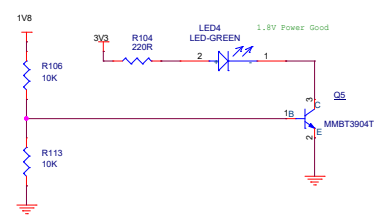

POWER INPUT 4

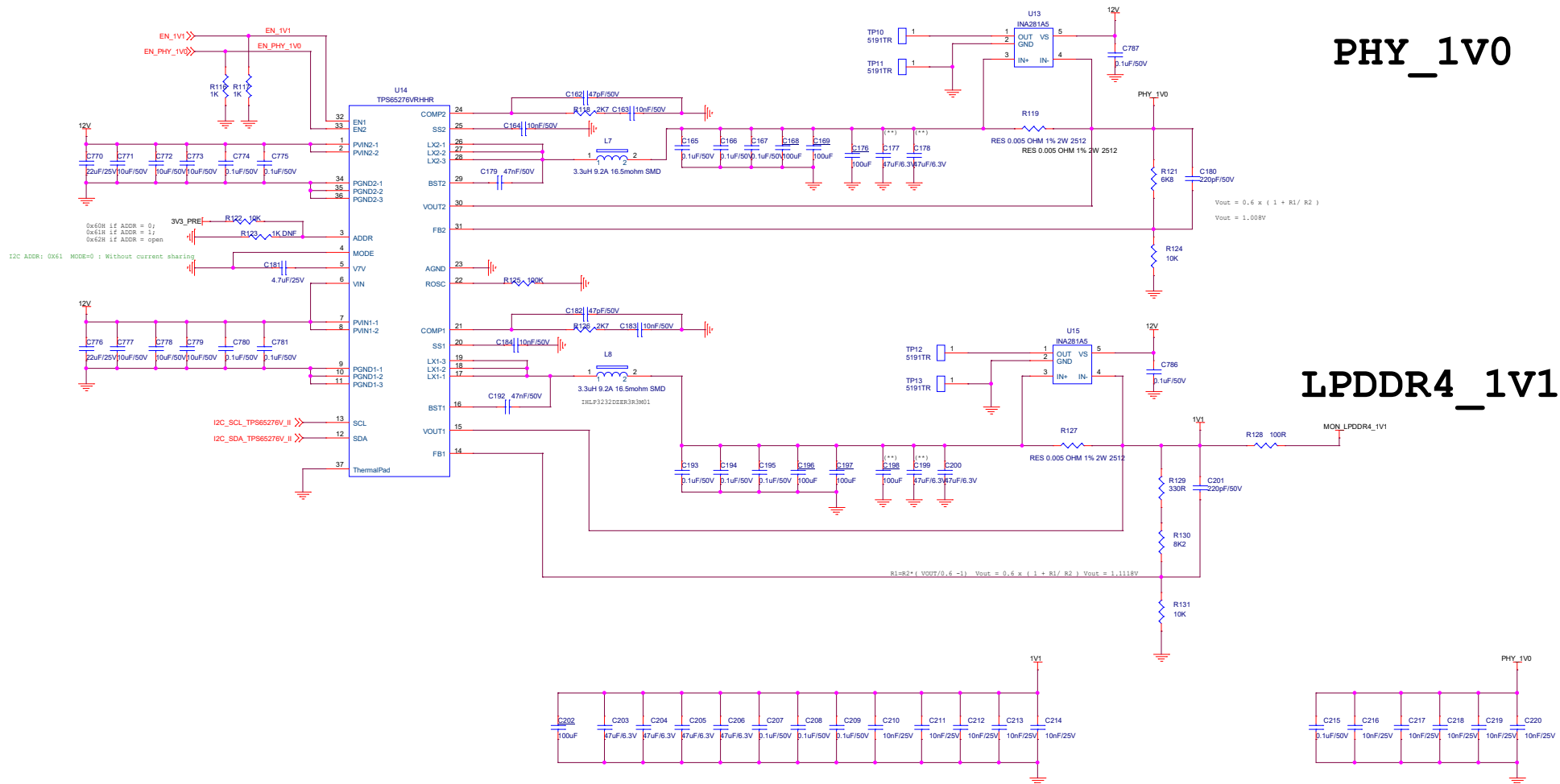

POWER INPUT 5

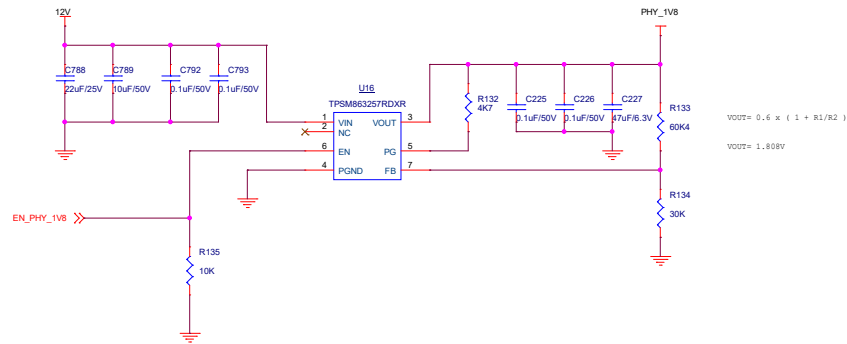

FMC_1V8

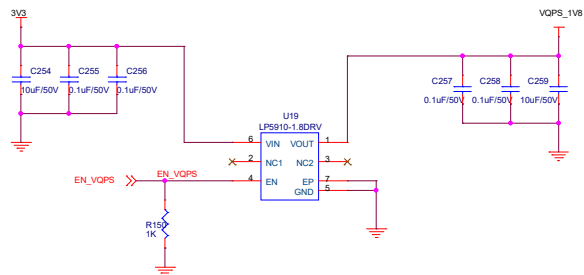
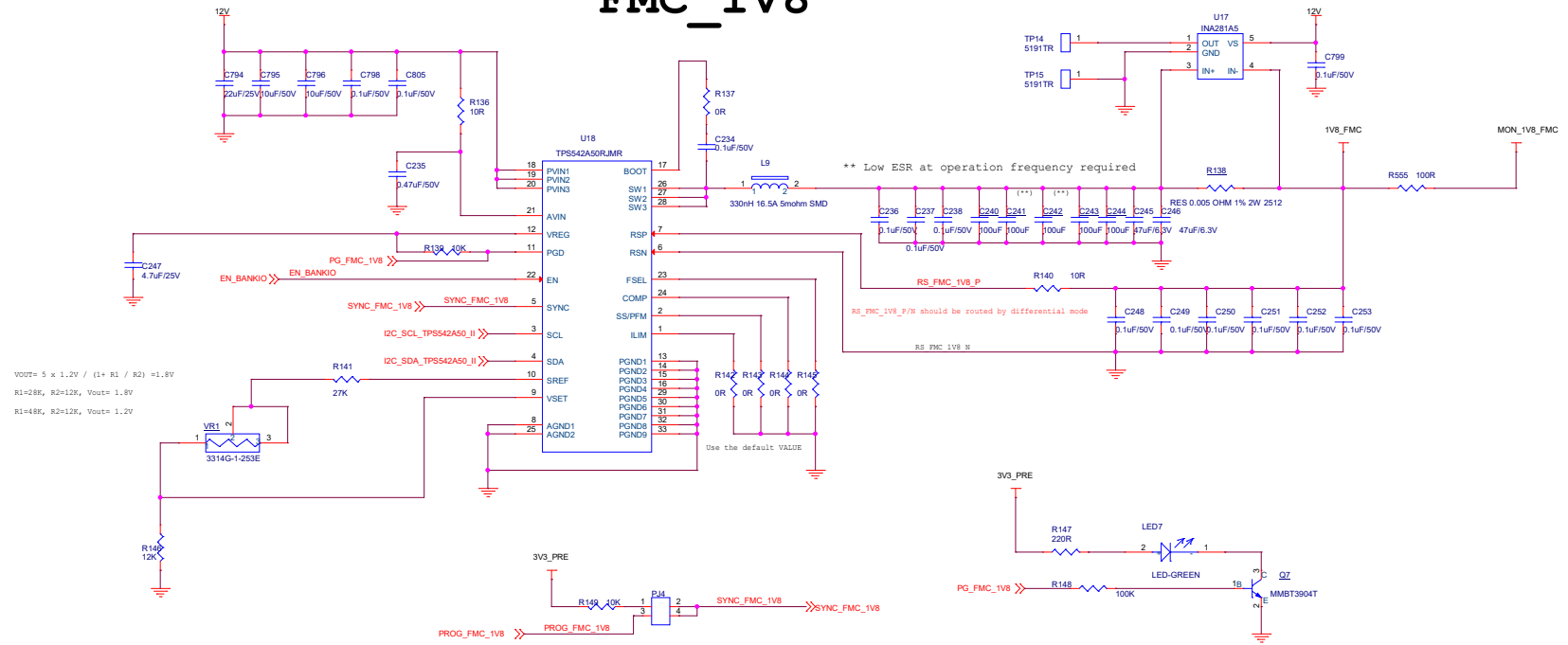

FPGA POWER

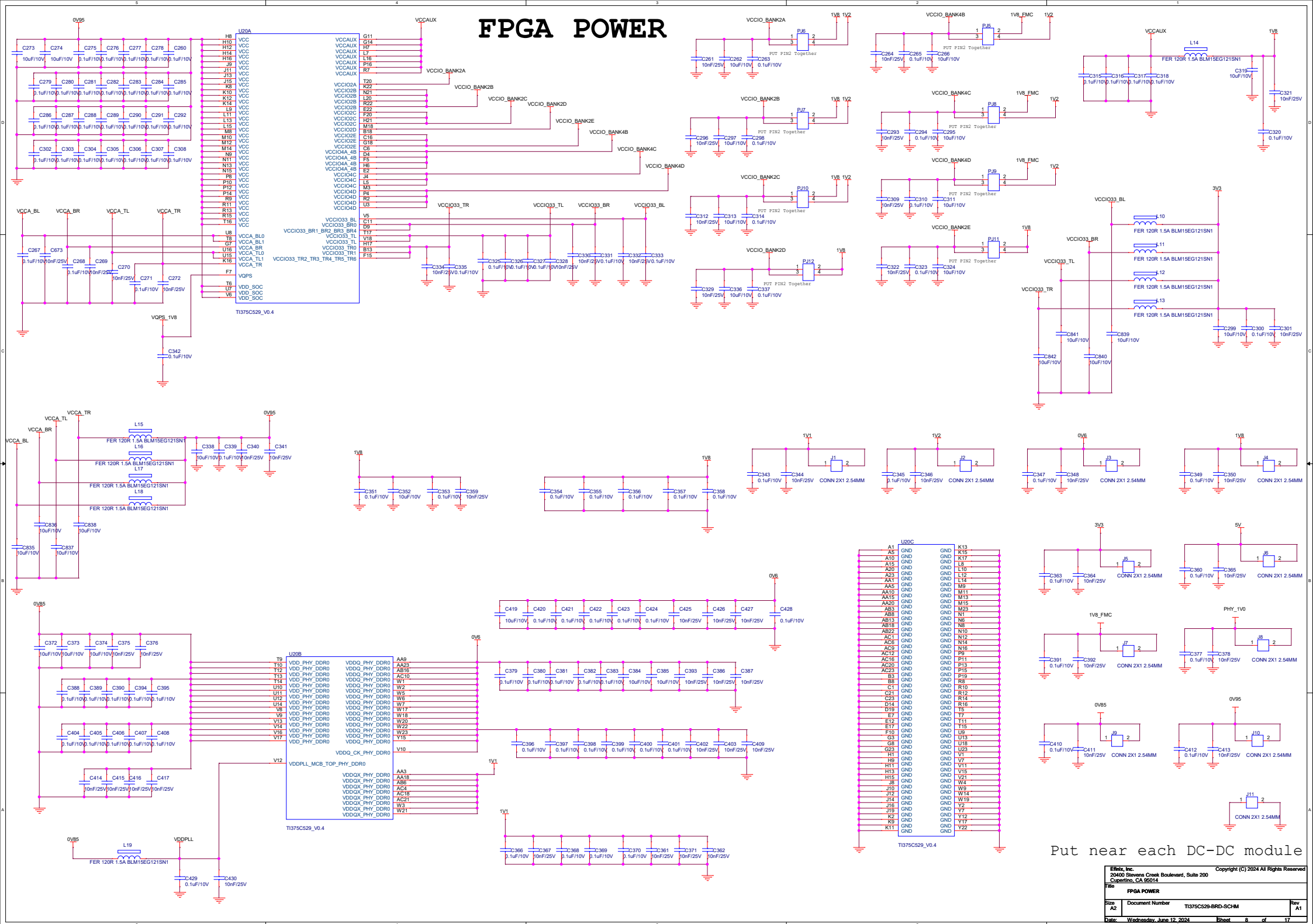

FPGA LPDDR4/4X INTERFACE

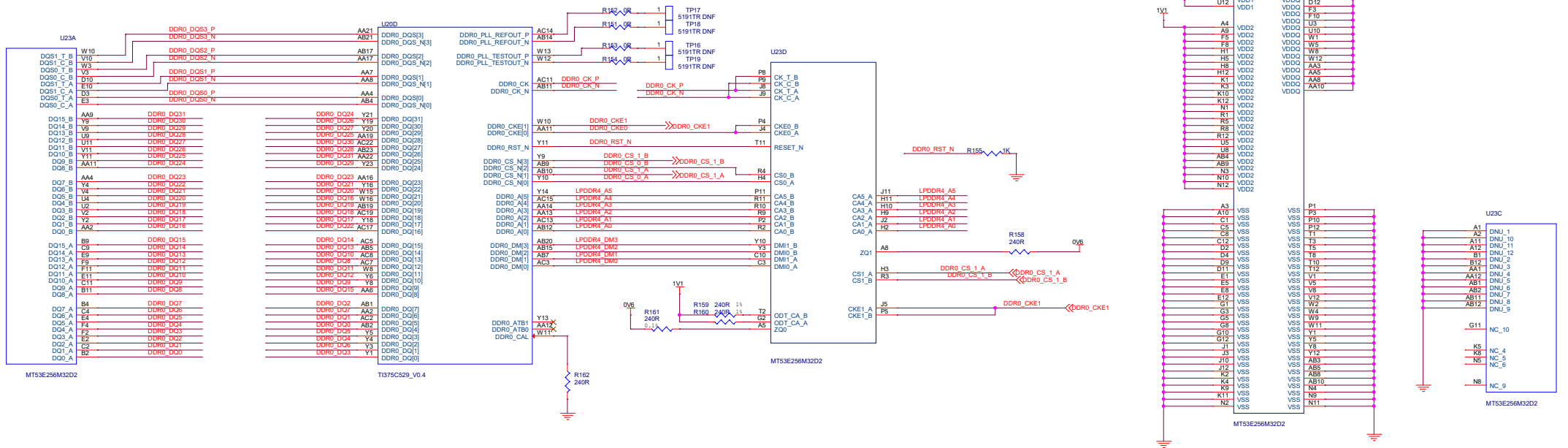

DQ signals can be swapped between one byte group

J21 is for LPDDR4

R475 and R165 is for LPDDR4X

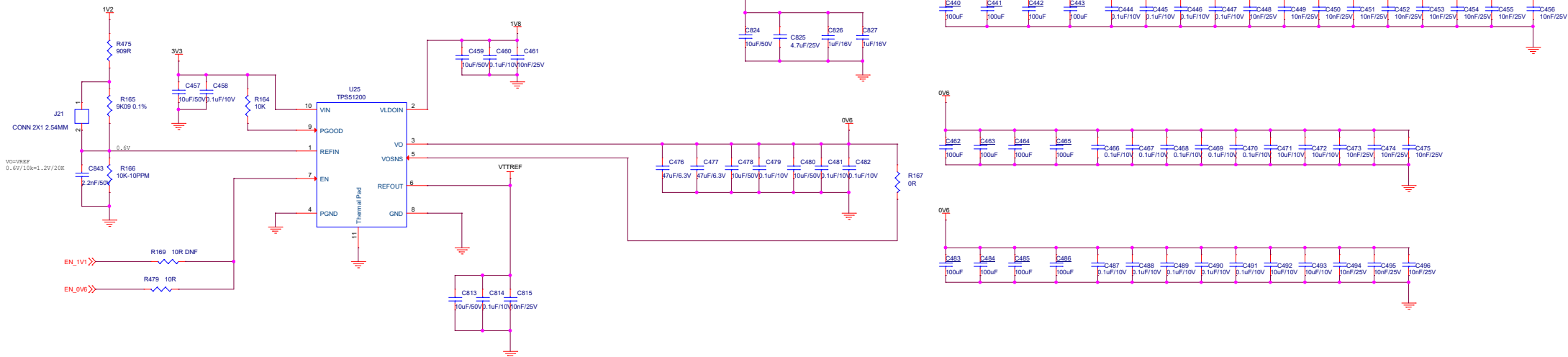

PMOD & OSC

1. 8V 25MHZ INPUT

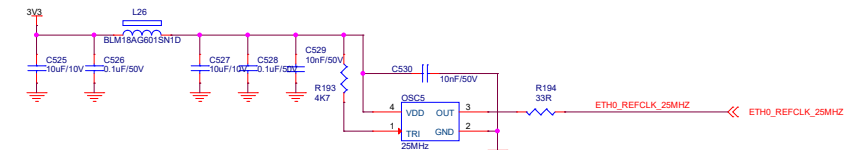
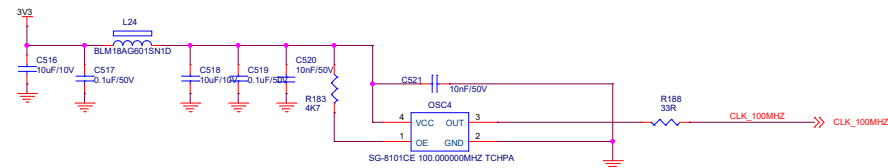
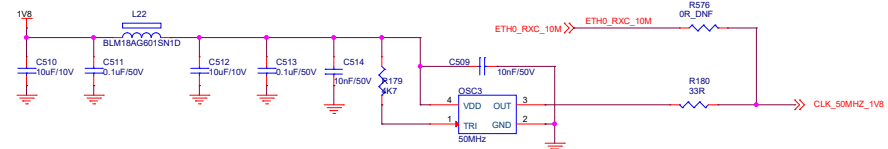
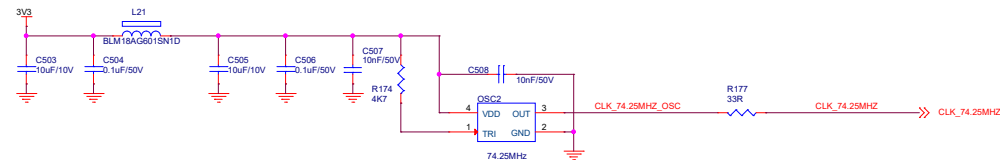
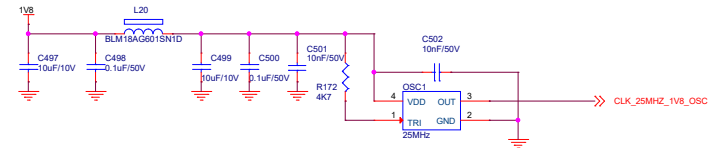
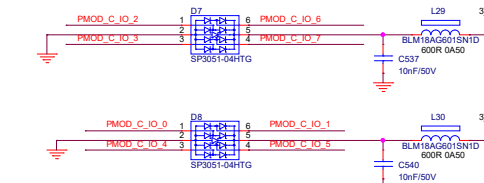
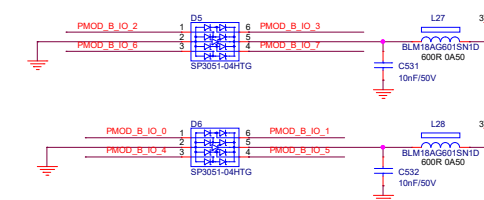
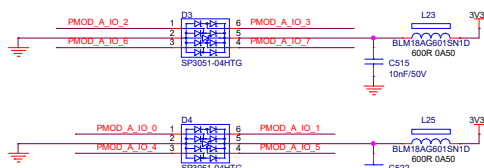
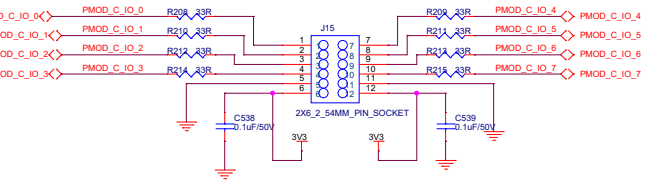
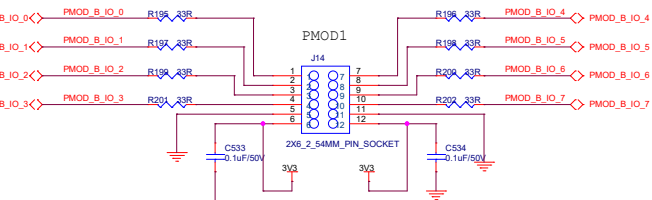
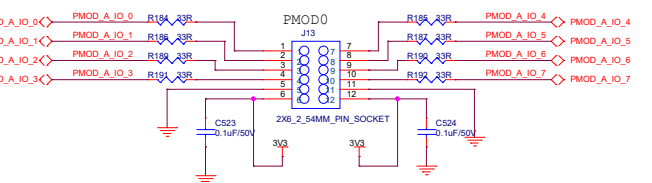
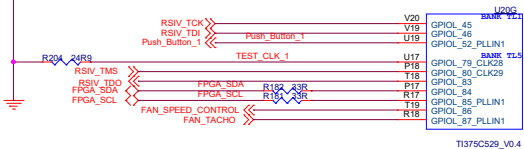
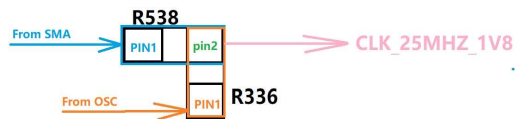
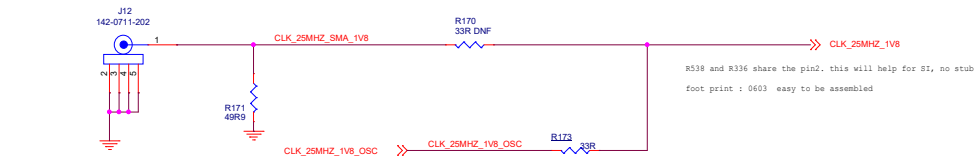

FPGA-MIPI INTERFACE

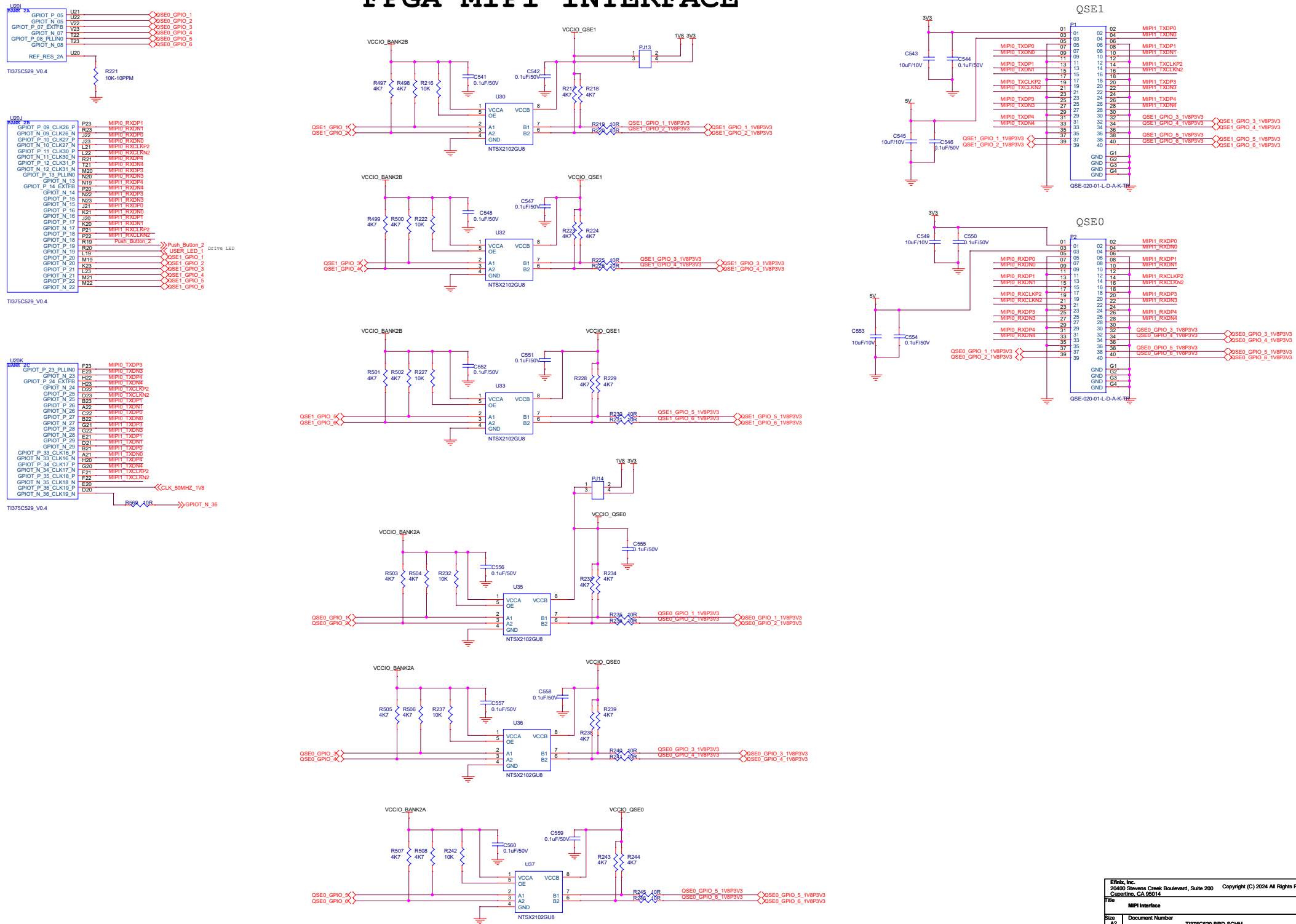

EMMC & FPGA - FMC

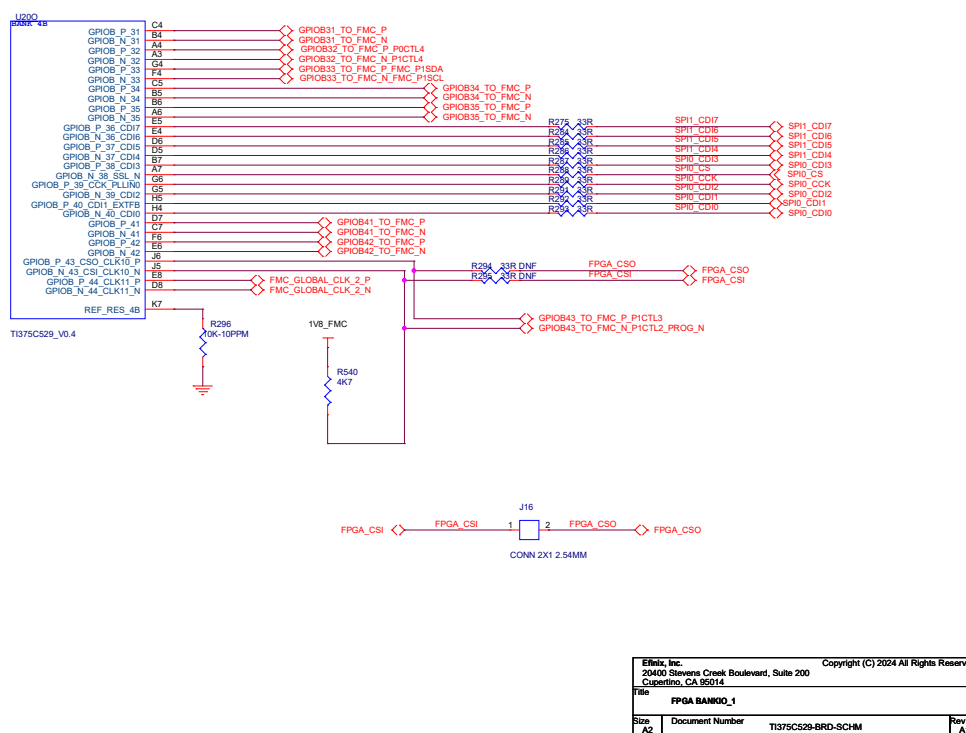
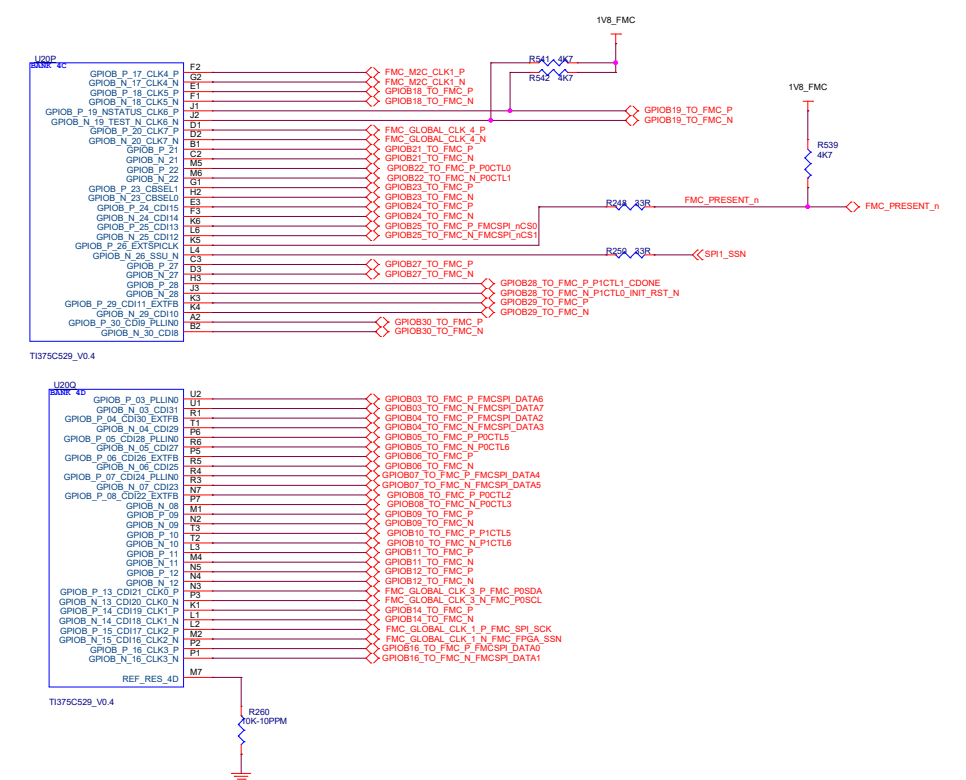
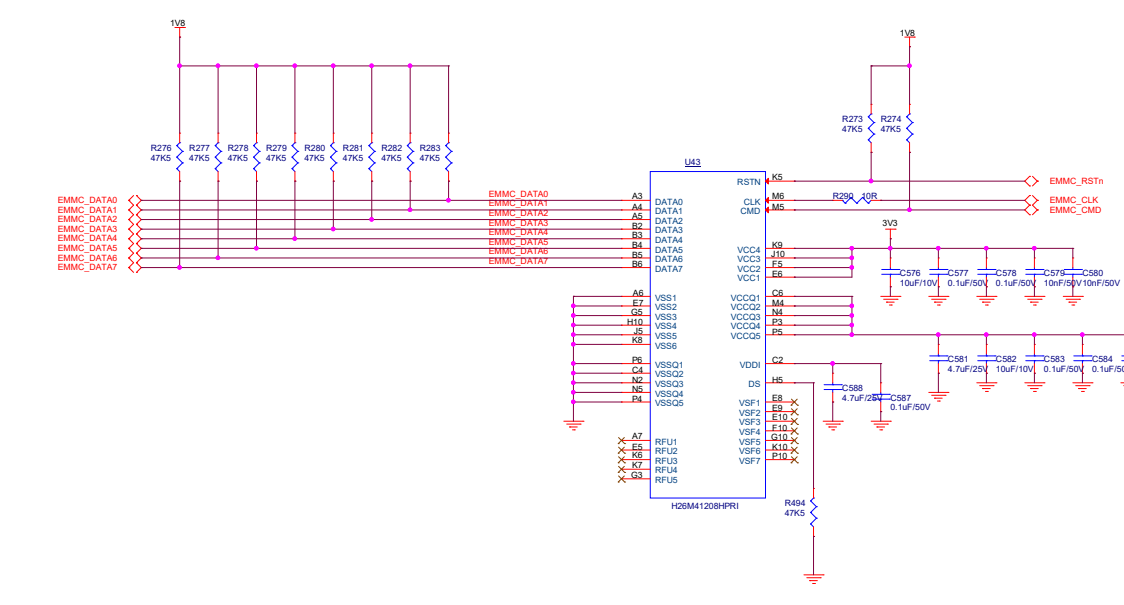
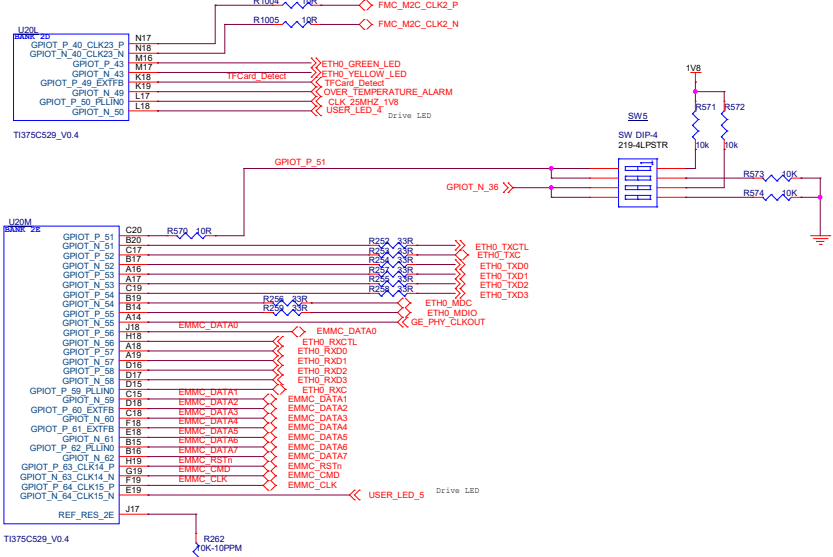
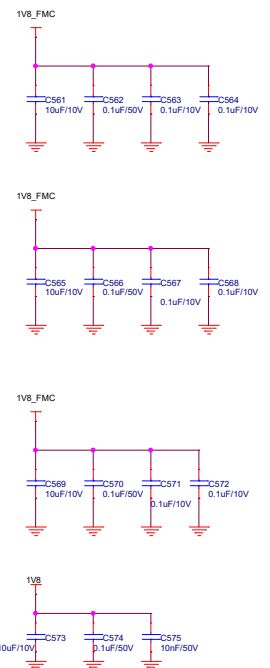

FMC CONNECTOR

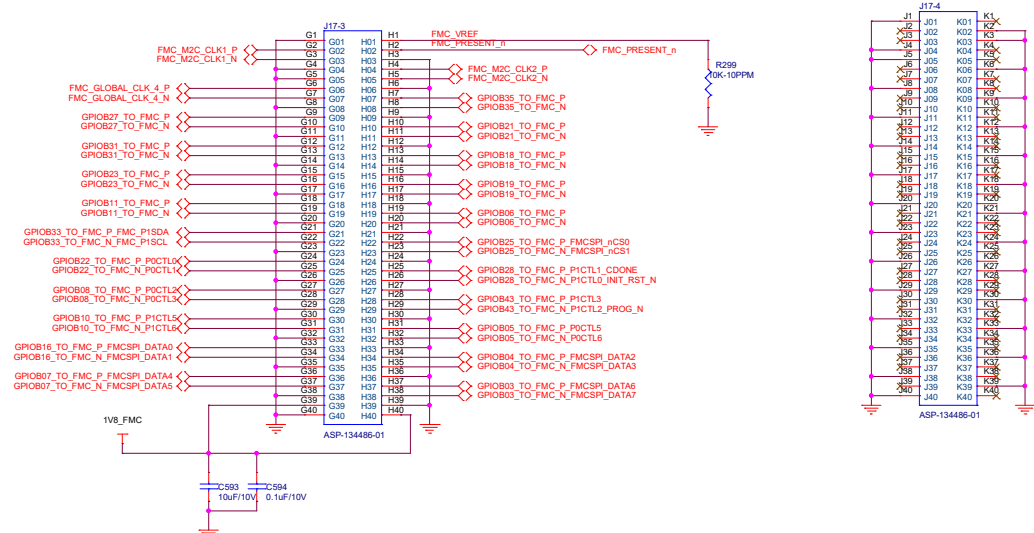
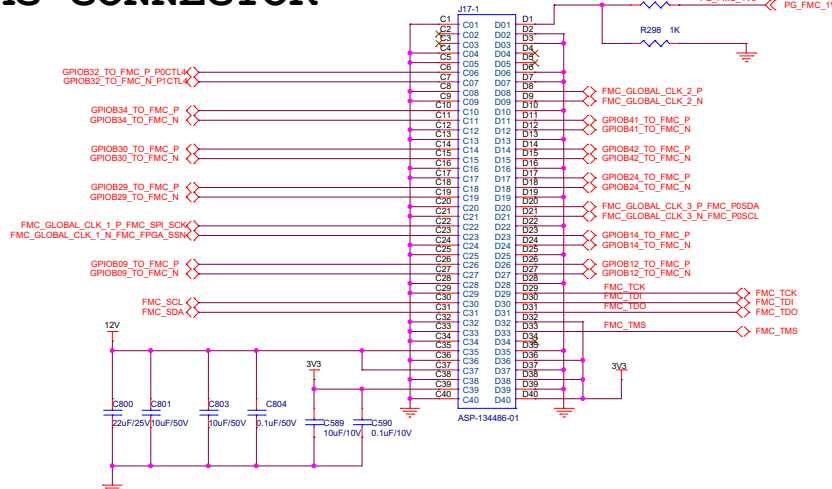
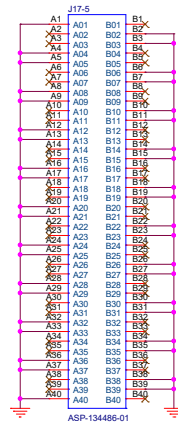

SPI FLASH & JTAG & FAN CONNECTOR

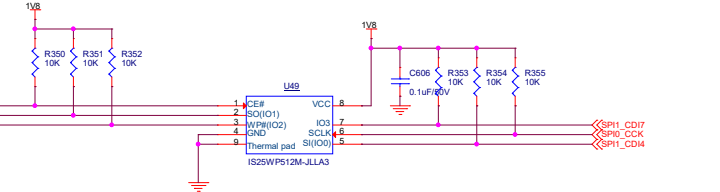
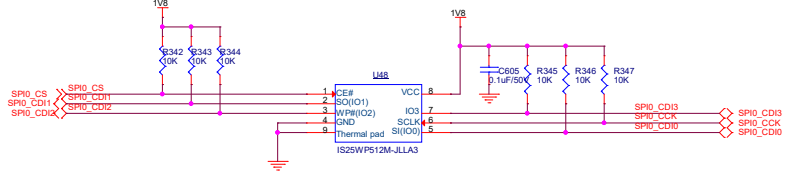
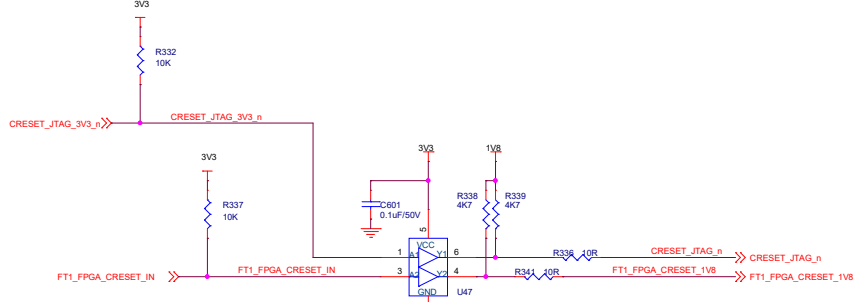
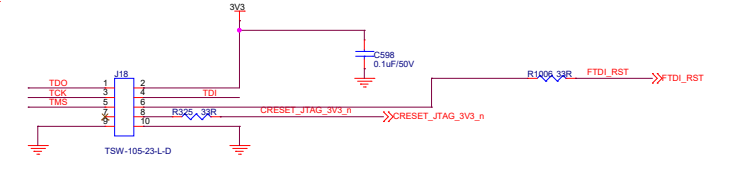
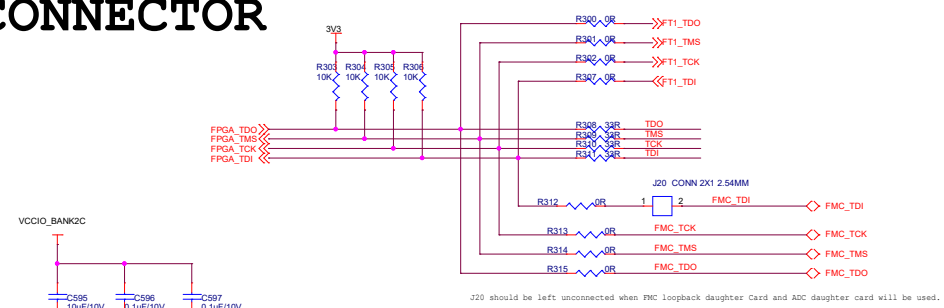
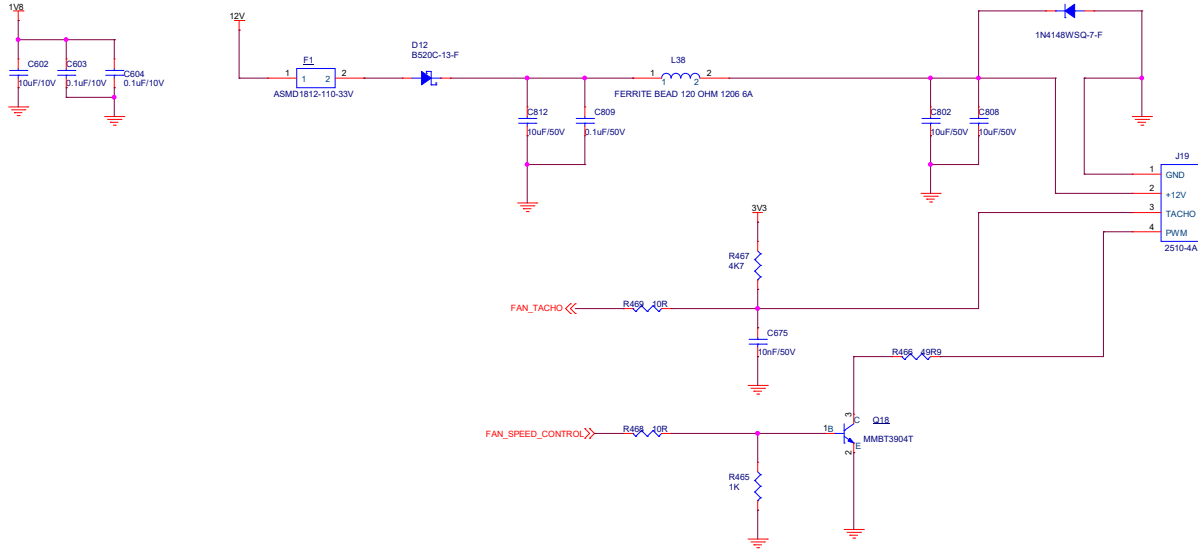
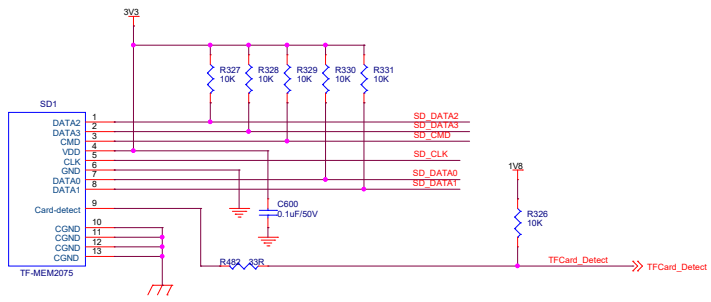
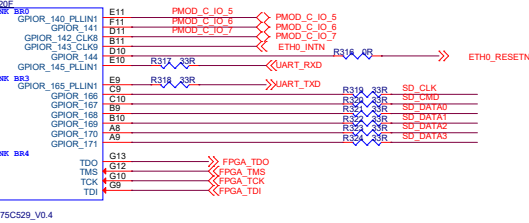
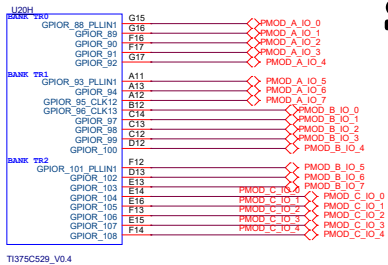

GE PHY

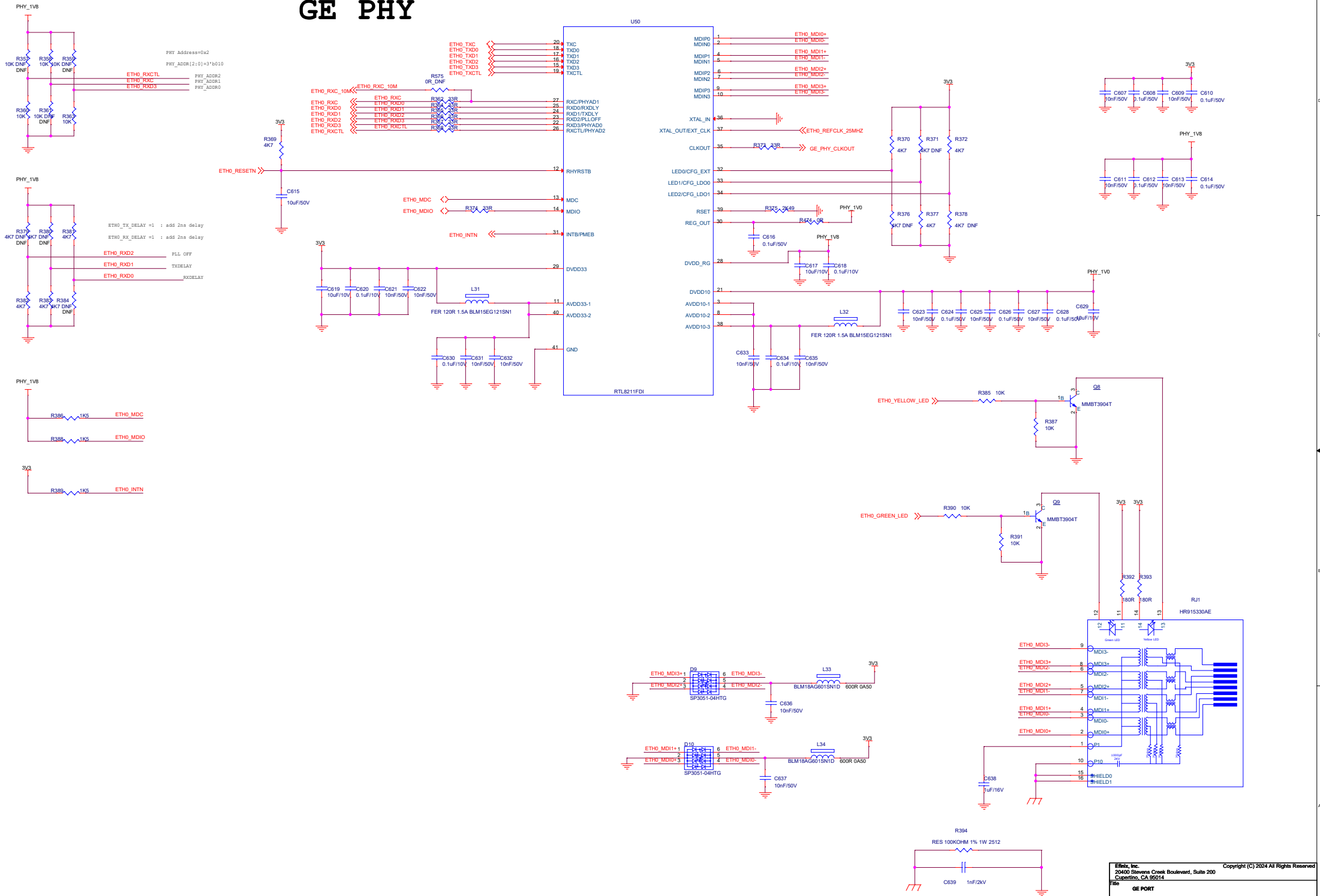

RTC & TEMPERATURE SENSOR

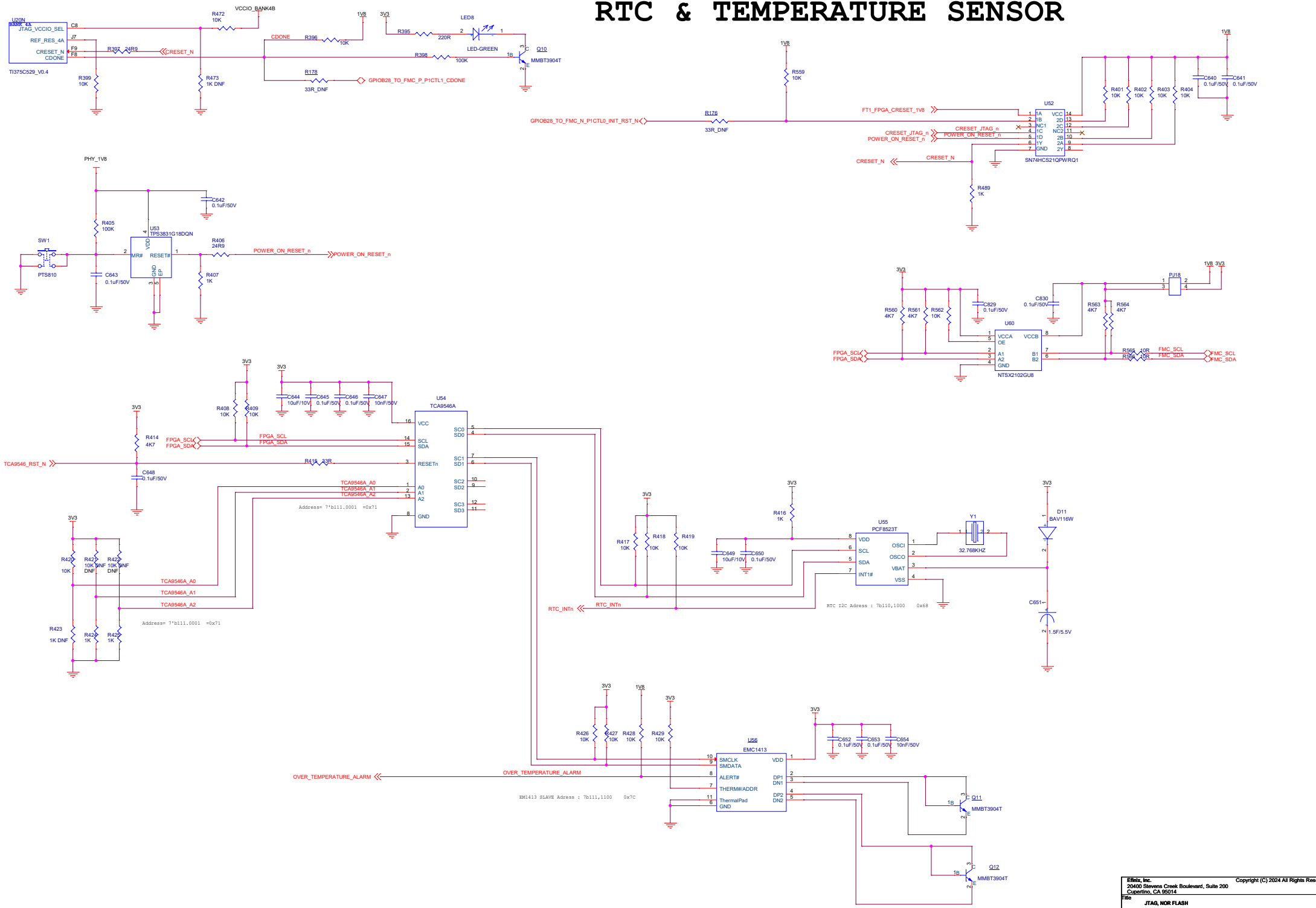

USB INTERFACE

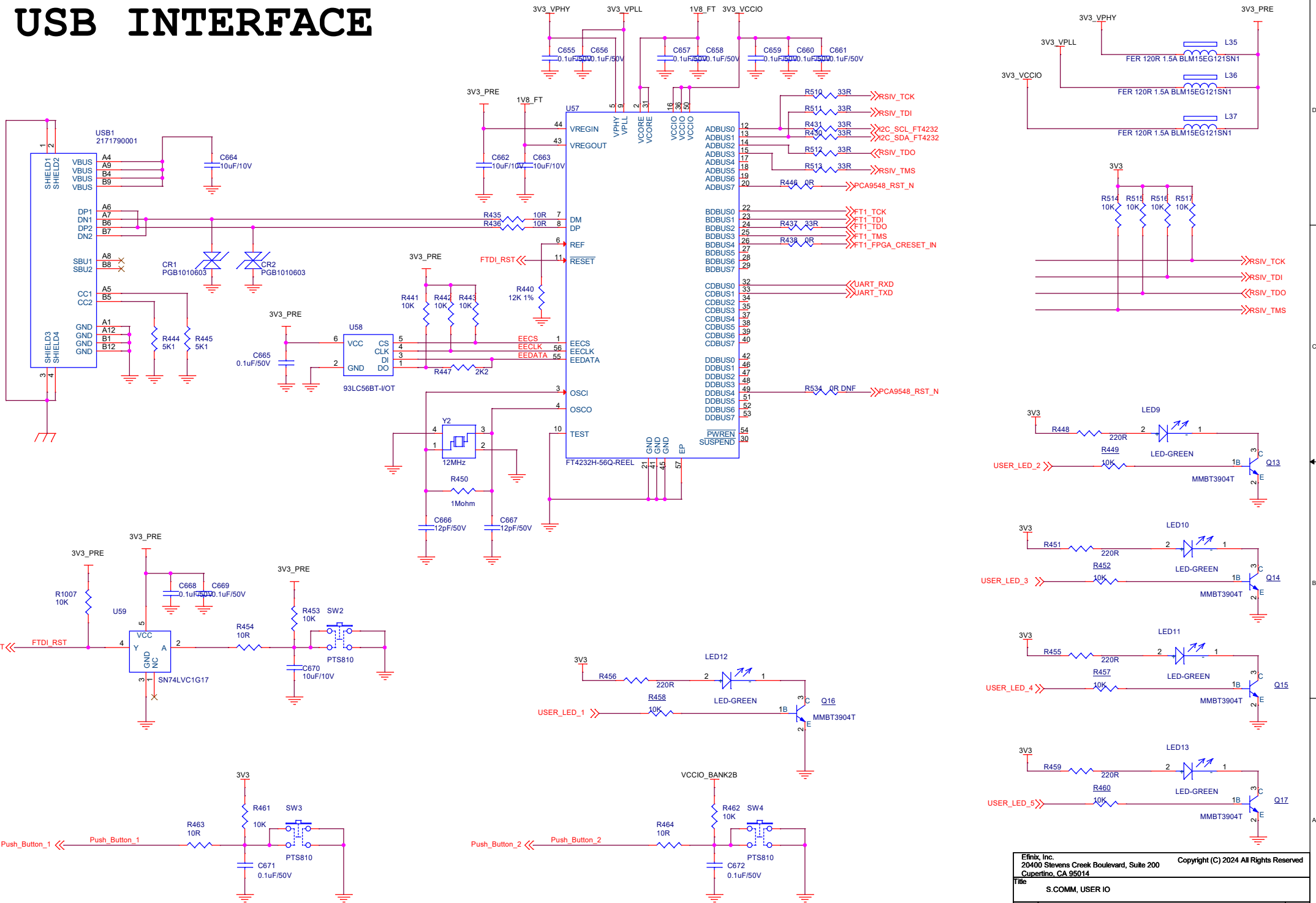

Efinix, Inc. 20400 Stevens Creek Boulevard, Suite 200 Cupertino, CA 95014		Copyright (C) 2024 All Rights Reserved
Title S.COMM, USER IO		
Size A3	Document Number T1375C529-BRD-SCHM	Rev A1
Date: Wednesday, June 12, 2024	Sheet 17 of 17	



Item	Qty	Part Type	Description	Value	Reference	Footprint	Manufacturing PN
1	2	Suppressors	ESD Suppressors	PGB1010603	CR1,CR2	SMD0603	PGB1010603
2	44	CAPACITOR	X7R, 10%, 10uF/50V,1206	10uF/50V	C9,C117,C254,C259,C457,C459,C478,C480,C615,C717,C720,C721,C726,C730,C732,C733,C736,C737,C738,C748,C749,C755,C756,C760,C761,C765,C771,C772,C773,C777,C778,C779,C789,C795,C796,C801,C802,C803,C808,C812,C813,C818,C821,C824	C1206	CL31B106KBHNNNE
3	36	CAPACITOR	X7R,0.1uF/50V, 10%, 0603	0.1uF/50V	C10,C716,C722,C723,C724,C727,C728,C731,C734,C739,C740,C745,C746,C751,C752,C753,C754,C758,C759,C764,C767,C768,C769,C774,C775,C780,C781,C786,C787,C792,C793,C798,C799,C804,C805,C809	C0603	CC0603KRX7R9BB104
4	5	CAPACITOR	MLCC 2.2NF 10% 50V X7R SMD0402	2.2nF/50V	C11,C120,C140,C160,C843	C0402	CC0402KRX7R9BB222
5	2	CAPACITOR	CAP CER 0.47UF 50V X7R 0603	0.47uF/50V	C12,C235	C0603	CC0603KRX7R9BB474
6	78	CAPACITOR	X7R, 10%, 0.1uF/50V	0.1uF/50V	C13,C14,C15,C16,C26,C27,C28,C29,C30,C31,C36,C37,C40,C41,C43,C55,C56,C57,C64,C65,C66,C67,C68,C69,C80,C81,C82,C91,C92,C93,C94,C95,C96,C110,C111,C112,C113,C114,C115,C118,C128,C129,C130,C131,C132,C133,C148,C149,C150,C151,C152,C153,C165,C166,C167,C193,C194,C195,C207,C208,C209,C215,C225,C226,C234,C236,C237,C238,C248,C249,C250,C251,C252,C253,C255,C256,C257,C258	C0402	CC0402KRX7R9BB104
7	43	CAPACITOR	X5R, 100uF 20%, 10V, Low ESR Required	100uF	C17,C18,C19,C20,C21,C22,C53,C58,C59,C83,C84,C87,C107,C134,C154,C168,C169,C176,C196,C197,C198,C202,C240,C241,C242,C243,C244,C440,C441,C442,C443,C462,C463,C464,C465,C483,C484,C485,C486,C831,C832,C833,C834	C1210	CC1210MKX5R6BB107
8	25	CAPACITOR	X5R, 47uF 6.3V 20%, 0805, Low ESR	47uF/6.3V	C23,C24,C62,C63,C88,C89,C108,C109,C135,C136,C155,C156,C177,C178,C199,C200,C203,C204,C205,C206,C227,C245,C246,C476,C477	C0805	CC0805MKX5R5BB476
9	11	CAPACITOR	X5R 4.7UF 10% 25V 0805	4.7uF/25V	C25,C38,C39,C42,C70,C181,C247,C581,C588,C819,C825	C0805	CL21A475KAQNNNE
10	4	CAPACITOR	MLCC 47PF 5% 50V 0402	47pF/50V	C45,C71,C162,C182	C0402	CC0402JRNPO9BN470
11	50	CAPACITOR	MLCC 10NF 10% 50V X7R SMD0402	10nF/50V	C46,C52,C72,C79,C116,C138,C158,C163,C164,C183,C184,C501,C502,C507,C508,C509,C514,C515,C520,C521,C522,C529,C530,C531,C532,C537,C540,C575,C579,C580,C585,C586,C607,C609,C611,C613,C621,C622,C623,C625,C627,C631,C632,C633,C635,C636,C637,C647,C654,C675	C0402	CC0402KRX7R9BB103
12	4	CAPACITOR	MLCC 47NF 10% 50V X7R 0402	47nF/50V	C60,C86,C179,C192	C0402	CC0402KRX7R9BB473
13	6	CAPACITOR	MLCC 220PF 5% 50V 0402	220pF/50V	C61,C90,C97,C137,C180,C201	C0402	CC0402JRNPO9BN221
14	3	CAPACITOR	MLCC 47NF 10% 50V X7R 0402	47nF/50V	C106,C121,C141	C0402	CC0402KRX7R9BB473
15	3	CAPACITOR	MLCC 22PF 5% 50V NP0 SMD 0402	22pF/50V	C119,C139,C159	C0402	CC0402JRNPO9BN220
16	1	CAPACITOR	MLCC 220PF 5% 50V 04022	220pF/50V	C157	C0402	CC0402JRNPO9BN221

Item	Qty	Part Type	Description	Value	Reference	Footprint	Manufacturing PN
17	79	CAPACITOR	MLCC 10NF 10% 25V X7R SMD0201	10nF/25V	C210,C211,C212,C213,C214,C216,C217,C218,C219,C220,C261,C264,C269,C270,C272,C293,C296,C301,C309,C312,C321,C322,C328,C329,C330,C332,C334,C340,C341,C344,C346,C348,C350,C359,C361,C362,C364,C365,C367,C371,C375,C376,C378,C386,C387,C392,C393,C402,C403,C409,C411,C413,C414,C415,C416,C417,C425,C426,C427,C430,C439,C448,C449,C450,C451,C452,C453,C454,C455,C456,C461,C473,C474,C475,C494,C495,C496,C673,C815	C0201	CC0201KRX7R8BB103
18	143	CAPACITOR	X5R 100NF 10% 10V 0201	0.1uF/10V	C260,C263,C265,C267,C268,C271,C275,C276,C277,C278,C279,C280,C281,C282,C283,C284,C285,C286,C287,C288,C289,C290,C291,C292,C294,C298,C300,C302,C303,C304,C305,C306,C307,C308,C310,C314,C315,C316,C317,C318,C320,C323,C325,C326,C327,C331,C333,C335,C337,C339,C342,C343,C345,C347,C349,C351,C353,C354,C355,C356,C357,C358,C360,C363,C366,C368,C369,C370,C377,C379,C380,C381,C382,C383,C388,C389,C390,C391,C394,C395,C396,C397,C398,C399,C400,C401,C404,C405,C406,C407,C408,C410,C412,C420,C421,C422,C423,C424,C428,C429,C431,C433,C434,C435,C436,C437,C438,C444,C445,C446,C447,C458,C460,C466,C467,C468,C469,C470,C479,C481,C482,C487,C488,C489,C490,C491,C563,C564,C567,C568,C571,C572,C590,C594,C596,C597,C603,C604,C618,C620,C630,C634,C814	C0201	CC0201KRX5R6BB104
19	66	CAPACITOR	MLCC 10UF 10% 10V X5R SMD0603	10uF/10V	C262,C266,C273,C274,C295,C297,C299,C311,C313,C319,C324,C336,C338,C352,C372,C373,C374,C384,C385,C419,C432,C471,C472,C492,C493,C497,C499,C503,C505,C510,C512,C516,C518,C525,C527,C543,C545,C549,C553,C561,C565,C569,C573,C576,C582,C589,C593,C595,C602,C617,C619,C629,C644,C649,C662,C663,C664,C670,C835,C836,C837,C838,C839,C840,C841,C842	C0603	CC0603KRX5R6BB106
20	78	CAPACITOR	X7R, 0.1uF/50V, 10%, 0402	0.1uF/50V	C498,C500,C504,C506,C511,C513,C517,C519,C523,C524,C526,C528,C533,C534,C538,C539,C541,C542,C544,C546,C547,C548,C550,C551,C552,C554,C555,C556,C557,C558,C559,C560,C562,C566,C570,C574,C577,C578,C583,C584,C587,C598,C600,C601,C605,C606,C608,C610,C612,C614,C616,C624,C626,C628,C640,C641,C642,C643,C645,C646,C648,C650,C652,C653,C655,C656,C657,C658,C659,C660,C661,C665,C668,C669,C671,C672,C829,C830	C0402	CC0402KRX7R9BB104
21	5	CAPACITOR	MLCC 1UF 10% 50V X7R SMD 0805	1uF/16V	C638,C820,C822,C826,C827	C0805	CC0805KKX7R9BB105
22	2	CAPACITOR	CAP CER 1808 1NF 2000V X7R 20%	1nF/2kV	C639,C828	C1808	CC1808KKX7RDBB102
23	1	CAPACITOR	1.5F -20%,+80% 5.5V THROUGH HOLE 21.5mmx7.5mm P=5.0mm	1.5F/5.5V	C651	RAD	DCL5R5155CF
24	2	CAPACITOR	MLCC 12PF 5% 50V NP0 SMD 0402	12pF/50V	C666,C667	C0402	CC0402JRNPO9BN120
25	14	CAPACITOR	X7R, 10%, 22uF/25V 1210	22uF/25V	C678,C718,C719,C725,C729,C735,C747,C757,C762,C770,C776,C788,C794,C800	C1210	CC1210KKX7R8BB226
26	2	SCHOTTKY DIODE	DIODE SCHOTTKY 20V 5A SMC	B520C-13-F	D1,D12	DO-SMC	B520C-13-F
27	1	DIODE	TVS DIODE 18VWM 29.2VC SMA	SMAJ18A	D2	SMA-DO214AC	SMAJ18A
28	8	TVS	TVS DIODE 6VWM 17VC SOT23-6	SP3051-04HTG	D3,D4,D5,D6,D7,D8,D9,D10	SOT23-6	SP3051-04HTG
29	1	DIODE	SWITCH SOD-123 110V 250MW	BAV116W	D11	SOD123	BAV116W

Item	Qty	Part Type	Description	Value	Reference	Footprint	Manufacturing PN
30	1	DIODE	75V 150mA SMD SOD-323	1N4148WSQ-7-F	D14	SOD-323	1N4148WSQ-7-F
31	1	CMC	CMC 6A 2LN 1K OHM SMD	ACM1211-102-2PL-TL01	FL1	SMD_12X11	ACM1211-102-2PL-TL01
32	1	FUSE	FUSE BOARD MOUNT 1.1A 33VDC SMD 1812	FUSE-1.1A-33VDC-1812	F1	F1812	ASMD1812-110-33V
33	15	CONNECTOR	CONN HEADER VERT 2X1 POS 2.54mm	CONN 2X1 2.54MM	J1,J2,J3,J4,J5,J6,J7,J8,J9,J10,J11,J16,J20,J21,J22	SIP2-2_54	X6521WV-2X01H-C60D30
34	1	SMA	CONN SMA JACK STR 50 OHM SMD	142-0711-202	J12	SMA	142-0711-202
35	3	CONNECTOR	CONN 12 Position Receptacle Connector 0.100" (2.54mm) Through Hole, Right Angle Gold	2X6_2_54MM_PIN_SOCKET	J13,J14,J15	2X6_2_54MM_PIN_SOCKET	A2541HWR-2x6P-6T
36	1	CONNECTOR	CONN ARRAY RCPT 160POS SMD GOLD	ASP-134603-01	J17	ASP-134486-01	ASP-134603-01
37	1	CONNECTOR	CONN HEADER VERT 10POS 2.54MM	A2541WV-2X5P	J18	CON5X2-2_54A	A2541WV-2X5P
38	1	CONNECTOR	CONN 2510 1*4PIN 2.54mm Trough Hole	2510-4A	J19	2510-4PIN	2510-4A
39	14	LED	LED GREEN CLEAR SMD0603 571nm 2V 0603	LED-GREEN	LED1,LED2,LED3,LED4,LED5,LED6,LED7,LED8,LED9,LED10,LED11,LED12,LED13,LED14	LED0603	LTST-C191KGKT
40	2	IND	FIXED IND 330NH 16.5A 5 MOHM SMD	330nH 16.5A 5mohm SMD	L1,L9	SMD-5_49mm X5_18mm	IHLP2020CZERR33M11
41	4	IND	FIXED IND 3.3UH 9.2A 17.7MOHM SMD	3.3uH 9.2A 16.5mohm SMD	L2,L3,L7,L8	SMD8_64mmx8_18mm	IHLP3232DZER3R3M01
42	3	IND	FIXED IND 4.7UH 6A 19.5 MOHM SMD	4.7uH 6.2A 19.5mohm SMD	L4,L5,L6	SMD_10_2mmx10_2mm	744311470
43	12	Ferrite	FERRITE BEAD 120 OHM 0402 1LN	FER 120R 1.5A BLM15EG121SN1	L10,L11,L12,L13,L14,L15,L16,L17,L18,L19,L31,L32	402	BLM15EG121SN1D
44	13	Ferrite	FERRITE BEAD 600 OHM 0603 1LN	BLM18AG601SN1D	L20,L21,L22,L23,L24,L25,L26,L27,L28,L29,L30,L33,L34	603	BLM18AG601SN1D
45	3	Ferrite	FERRITE BEAD 120 OHM 0402 1LN02	FER 120R 1.5A BLM15EG121SN1	L35,L36,L37	402	BLM15EG121SN1D
46	1	Ferrite	FERRITE BEAD 160 OHM 6A 1206 1LN06	FERRITE BEAD 120 OHM 1206 6A	L38	L1206	HI1206T161R-10
47	2	OSCILLATOR	XTAL OSC 25MHZ+/-50PPM, HCMOS, SMD-4PIN, 1.6V ~ 3.6V, Enable/Disable , No Lead	25MHz	OSC1,OSC5	OSC2520	SG-210STF 25.0000MS3
48	1	OSCILLATOR	MEMS OSC XO 74.2500MHZ+/-20ppm, LVCMOS, LVTTTL Oscillator 3.3V, Enable/Disable, 4-SMD, No Lead	74.25MHz	OSC2	OSC2520	SG-8101CG-74.250000MHZ-TBGSA
49	1	OSCILLATOR	XTAL OSC 50MHZ+/-30PPM, HCMOS, SMD-4PIN, 1.71V ~ 3.63V, Enable/Disable , No Lead	50MHz	OSC3	OSC2520	MC2520Z50.0000C19XSH
50	1	OSCILLATOR	XTAL OSC XO 100.000000MHZ CMOS SMD	SG-8101CE 100.000000MHZ TCHPA	OSC4	3225-4PIN	SG-8101CE 100.000000MHZ TCHPA

Item	Qty	Part Type	Description	Value	Reference	Footprint	Manufacturing PN
51	1	CONNECTOR	CONN PWR JACK 2.5X5.5MM SOLDER, 2.5A, Horizontal, Surface Mount (SMT), Dc Power Jack Connector	DC-044D-2.5A-2.5-SMT	PJ1	DC-044D-2.5A-2.5-SMT	DC-044D-2.5A-2.5-SMT
52	14	CONNECTOR	CONN HEADER VERT 2X2POS 2.54mm	CONN 2X2 2.54MM	PJ3,PJ4,PJ5,PJ6,PJ7,PJ8,PJ9,PJ10,PJ11,PJ12,PJ13,PJ14,PJ17,PJ18	CON2X2-2_54A	A2541WV-2x2P-6T
53	1	SWITCH	SPDT, 3PIN, AC-125V,DC-50V, 3A, DIP SW3_13X6.8MM_TM	SS-12D10L5	PSW1	TH	SS-12D10L5
54	2	CONNECTOR	0.80 mm Q Strip High-Speed Ground Plane Socket Strip	QSE-020-01-L-D-A-K-TR	P1,P2	QSE-020-01-X-D-A	QSE-020-01-L-D-A-K-TR
55	18	TRANSISTOR	60V NPN SMALL SIGNAL TRANSISTOR IN SOT523	MMBT3904T-7-F	Q1,Q2,Q3,Q4,Q5,Q6,Q7,Q8,Q9,Q10,Q11,Q12,Q13,Q14,Q15,Q16,Q17,Q18	SOT523	MMBT3904T-7-F
56	1	RJ45	100/1000Base-T Magnetics single Port RJ45 connector with Integrated Magnetics and LEDS	HR915330AE	RJ1	RJ45-TH_HR911130A	HR915330AE
57	43	RESISTOR	RES 1/16W 10R 1% SMD0402	10R	R1,R5,R42,R43,R44,R46,R48,R49,R55,R57,R61,R62,R136,R140,R219,R220,R225,R226,R230,R231,R235,R236,R240,R241,R245,R246,R290,R336,R341,R435,R436,R454,R463,R464,R468,R469,R479,R565,R566,R569,R570,R1004,R1005	R0402	RC0402FR-0710RL
58	37	RESISTOR	RES 1/16W 0R SMD0402	0R	R2,R10,R11,R12,R13,R84,R85,R89,R91,R93,R94,R95,R98,R100,R137,R142,R143,R144,R145,R151,R152,R153,R154,R167,R300,R301,R302,R307,R312,R313,R314,R315,R316,R438,R446,R474,R554	R0402	RC0402JR-070RL
59	1	RESISTOR	2.5 mOhms 1% 2W Chip Resistor 2512 (6432 Metric) Automotive AEC-Q200, Current Sense, Moisture Resistant, Pulse Withstanding Metal Element	RES 0.0025 OHM 1% 2W 2512	R3	R2512	LR2512-22R0025F4
60	118	RESISTOR	RES 1/16W 10K 1% SMD0402	10K	R4,R20,R21,R22,R23,R24,R25,R26,R27,R28,R29,R30,R31,R32,R33,R34,R35,R52,R54,R73,R82,R87,R88,R92,R96,R97,R103,R106,R113,R114,R115,R122,R124,R131,R135,R139,R149,R164,R216,R222,R227,R232,R237,R242,R303,R304,R305,R306,R326,R327,R328,R329,R330,R331,R332,R337,R342,R343,R344,R345,R346,R347,R350,R351,R352,R353,R354,R355,R358,R360,R363,R385,R387,R390,R391,R396,R399,R401,R402,R403,R404,R408,R409,R417,R418,R419,R420,R426,R427,R428,R429,R441,R442,R443,R453,R461,R462,R472,R481,R514,R515,R516,R517,R553,R557,R558,R559,R562,R571,R572,R573,R574,R1003,R449,R452,R457,R458,R460	R0402	RC0402FR-0710KL
61	20	RESISTOR	RES 1/16W 1K 1% SMD0402	1K	R6,R39,R40,R41,R56,R59,R65,R66,R72,R116,R117,R150,R155,R298,R407,R416,R424,R425,R465,R489	R0402	RC0402FR-071KL
62	1	RESISTOR	RES 1/16W 62K 1% SMD0402	62K	R7	R0402	RC0402FR-0762KL
63	52	RESISTOR	RES 1/16W 4K7 1% SMD0402	4K7	R8,R47,R108,R132,R172,R174,R179,R183,R193,R217,R218,R223,R224,R228,R229,R233,R234,R238,R239,R243,R244,R338,R339,R369,R370,R372,R377,R381,R382,R383,R414,R467,R497,R498,R499,R500,R501,R502,R503,R504,R505,R506,R507,R508,R539,R540,R541,R542,R560,R561,R563,R564	R0402	RC0402FR-074K7L
64	1	RESISTOR	RES 82K 0.1% 1/16W SMD 0402	82K 0.1%	R9	R0402	RT0402BRE0782KL
65	1	RESISTOR	RES 1/16W 135K 1% SMD0402	135K	R14	R0402	RN73H1ETTP1353F50

Item	Qty	Part Type	Description	Value	Reference	Footprint	Manufacturing PN
66	1	RESISTOR	RES 1/16W 15K8 1% SMD0402	15K8	R15	R0402	RC0402FR-0715K8L
67	3	RESISTOR	RES 1/16W 30K 1% SMD0402	30K	R16,R17,R134	R0402	RC0402FR-0730KL
68	12	RESISTOR	RES 1/16W 220R 1% SMD0402	220R	R18,R63,R76,R104,R105,R107,R147,R395,R451,R455,R459,R1002	R0402	RC0402FR-07220RL
69	8	RESISTOR	RES 1/16W 100K 1% SMD0402	100K	R19,R50,R74,R79,R125,R148,R398,R405	R0402	RC0402FR-07100KL
70	1	RESISTOR	RES 1/16W 10R 1% SMD0402	10R	R45	R0402	RC0402FR-0710RLL
71	4	RESISTOR	RES 1/16W 2K7 1% SMD0402	2K7	R67,R75,R118,R126	R0402	RC0402FR-072K7L
72	5	RESISTOR	RES 1/16W 100R 1% SMD0402	100R	R68,R78,R128,R555,R556	R0402	RC0402FR-07100RL
73	8	RESISTOR	RES 0.005 OHM 1% 2W 2512	RES 0.005 OHM 1% 2W 2512	R69,R77,R83,R90,R99,R119,R127,R138	R2512	PA2512FKE7W0R005E
74	1	RESISTOR	RES 1/16W 45K 1% SMD0402	45K	R70	R0402	RC0402FR-0745KL
75	1	RESISTOR	RES 1/16W 1K4 1% SMD0402	1K4	R80	R0402	RC0402FR-071K4L
76	1	RESISTOR	RES 1/16W 2K87 1% SMD0402	2K87	R81	R0402	RC0402FR-072K87L
77	1	RESISTOR	RES 1/16W 20K 1% SMD0402	20K	R86	R0402	RC0402FR-0720KL
78	1	RESISTOR	RES 1/16W 36K5 1% SMD0402	36K5	R101	R0402	RC0402FR-0736K5L
79	1	RESISTOR	RES 1/16W 4K99 1% SMD0402	4K99	R102	R0402	RC0402FR-074K99L
80	1	RESISTOR	RES 1/16W 42K2 1% SMD0402	42K2	R109	R0402	RC0402FR-0742K2L
81	1	RESISTOR	RES 1/16W 6K8 1% SMD0402	6K8	R121	R0402	RC0402FR-076K8L
82	1	RESISTOR	RES 1/16W 330R 1% SMD0402	330R	R129	R0402	RC0402FR-07330RL
83	1	RESISTOR	RES 1/16W 8K2 1% SMD0402	8K2	R130	R0402	RC0402FR-078K2L
84	1	RESISTOR	RES 1/16W 60K4 1% SMD0402	60K4	R133	R0402	RC0402FR-0760K4L
85	1	RESISTOR	RES 1/16W 27K 1% SMD0402	27K	R141	R0402	RC0402FR-0727KL
86	1	RESISTOR	RES 1/16W 12K 1% SMD0402	12K	R146	R0402	RC0402FR-0712KL
87	5	RESISTOR	RES 240 OHM 1% 1/16W 0402	240R	R158,R159,R160,R161,R162	R0402	RC0402FR-07240RL
88	1	RESISTOR	RES 9.09K OHM 0.1% 1/16W 0402	9K09 0.1%	R165	R0402	RP0402BRD079K09L
89	6	RESISTOR	RES10KOHM 0.1% 1/16W 0402 10ppmC	10K-10PPM	R166,R221,R260,R262,R296,R299	R0402	RT0402BRE0710KL
90	2	RESISTOR	RES 1/16W 49.9R 1% SMD0402	49R9	R171,R466	R0402	RC0402FR-0749R9L
91	81	RESISTOR	RES 1/16W 33R 1% SMD0402	33R	R173,R177,R180,R181,R182,R184,R185,R186,R187,R188,R189, R190,R191,R192,R194,R195,R196,R197,R198,R199,R200,R201, R202,R208,R209,R210,R211,R212,R213,R214,R215,R248,R250, R252,R253,R254,R255,R256,R257,R258,R259,R275,R284,R285, R286,R287,R288,R289,R291,R292,R293,R308,R309,R310,R311, R317,R318,R319,R320,R321,R322,R323,R324,R325,R362,R364, R365,R366,R367,R368,R373,R374,R415,R430,R431,R437,R482, R510,R511,R512,R513	R0402	RC0402FR-0733RL
92	4	RESISTOR	RES 1/16W 24.9R 1% SMD0402	24R9	R204,R205,R397,R406	R0402	RC0402FR-0724R9L
93	12	RESISTOR	RES 1/16W 47.5K 1% SMD0402	47K5	R273,R274,R276,R277,R278,R279,R280,R281,R282,R283,R494, R551	R0402	RC0402FR-0747K5L
94	1	RESISTOR	RES 2.49K 1% 1/16W SMD0402	2K49	R375	R0402	RC0402FR-072K49L
95	3	RESISTOR	RES 1/16W 1K5 1% SMD0402	1K5	R386,R388,R389	R0402	RC0402FR-071K5L
96	2	RESISTOR	RES 1/16W 180R 1% SMD0402	180R	R392,R393	R0402	RC0402FR-07180RL

Item	Qty	Part Type	Description	Value	Reference	Footprint	Manufacturing PN
97	2	RESISTOR	RES 100KOHM 1% 1W 2512	RES 100KOHM 1% 1W 2512	R394,R543	R2512	CRCW2512100KFKEG
98	1	RESISTOR	RES 1/16W 12K 1% SMD0402	12K 1%	R440	R0402	RC0402FR-0712KL
99	2	RESISTOR	RES 1/16W 5K1 1% SMD0402	5K1	R444,R445	R0402	RC0402FR-075K1L
100	1	RESISTOR	RES 1/16W 2K2 1% SMD0402	2K2	R447	R0402	RC0402FR-072K2L
101	2	RESISTOR	RES 1/16W 220R 1% SMD0402	220R	R448,R456	R0402	RC0402FR-07220RL
102	1	RESISTOR	RES 1/16W 1M 1% SMD0402	1Mohm	R450	R0402	RC0402FR-071ML
103	1	RESISTOR	RES SMD 909 OHM 0.1% 1/16W 0402	909R	R475	R0402	RT0402BRE07909RL
104	2	RESISTOR	RES 1/16W 28K 1% SMD0402	28K	R480,R1001	R0402	RC0402FR-0728KL
105	1	SD	MICRO SD PUSH-PUSH, SMT, 1.40MM, 9 (8 + 1) Position Card Connector Secure Digital, Right Angle Gold	MEM2075-00-140-01-A	SD1	TF-MEM2075	MEM2075-00-140-01-A
106	4	SWITCH	3.9N, 16VDC, 50mA	PTS810	SW1,SW2,SW3,SW4	PTS810	PTS810SJG250SMTRLFS
107	1	SWITCH	SWITCH SLIDE DIP SPST 100MA 20V	SW DIP-4	SW5	SW-DIP-4_127-DSHP04TSGET	DSHP04TSGET
108	15	TEST POINT	Color Keyed SMT Test Point -Black P/N 5191TR	5191TR	TP1,TP2,TP3,TP4,TP5,TP6,TP7,TP8,TP9,TP10,TP11,TP12,TP13,TP14,TP15	TP-RECT3X2_5-5191TR	5191TR
109	1	CONNECTOR	Universal Serial Bus (USB) Shielded I/O Receptacle, Type C, Right-Angle, Surface Mount, Top Mount, Single Row, 16 Circuits, Gold (Au) Plating	2171790001	USB1	2171790001	2171790001
110	7	IC	IC Current SENSE Amplifier 1 CIRCUIT SOT23-5	INA281A5	U1,U6,U8,U9,U11,U15,U17	SOT23-5	INA281A5IDBVT
111	2	IC	IC REG BUCK ADJ 15A 33VQFN	TPS542A50RJMR	U2,U18	VQFN-HR	TPS542A50RJMR
112	2	IC	Non-Isolated PoL Module DC DC Converter 1 Output 0.6 ~ 5.5V 3A 3V - 17V Input	TPSM863257RDXR	U3,U16	QFN-7PIN	TPSM863257RDXR
113	1	IC	IC INTERFACE SPECIALIZED 24TSSOP	PCA9548APW	U4	TSSOP24	PCA9548APW
114	1	IC	IC SUPERVISOR 8 CHANNEL 32VQFN	UCD9081RHBR	U5	VQFN-32	UCD9081RHBR
115	2	IC	IC REG BUCK PROG DL 36VQFN	TPS65276VRHHR	U7,U14	VQFN-36PIN	TPS65276VRHHR
116	1	IC	IC REG BUCK PROG TRPL 32VQFN	TPS65263RHBT	U10	VQFN-32PIN	TPS65263RHBT
117	1	IC	Linear Voltage Regulator IC Positive Fixed 1 Output 300mA 6-WSON (2x2)	LP5910-1.8DRV	U19	WSON-6PIN	LP5910-1.8DRVR
118	1	IC	EFINIX FPGA	TI375C529	U20	FBGA529	TI375C529
119	1	MEMORY	IC DRAM 8GBIT 2.133GHZ 200WFBGA	MT53E256M32D2	U23	WFBGA-200P	MT53E256M32D2DS-046
120	1	IC	IC REG CONV DDR 1OUT 10VSON	TPS51200	U25	VSON-10PIN	TPS51200DRC
121	7	IC	IC TRANSLTR BIDIRECTIONAL Voltage Level Translator 1 Circuit 2 Channel 50Mbps 8-XQFN 1.4x1.2	NTSX2102GU8	U30,U32,U33,U35,U36,U37,U60	XQFN8	NTSX2102GU8

Item	Qty	Part Type	Description	Value	Reference	Footprint	Manufacturing PN
122	1	IC	IC E-NAND/FLASH -40??-85??/NAND/STACK/8GBX1/153FBGA	H26M41208HPRI	U43	FBGA-153	H26M41208HPRI
123	1	IC	IC BUFFER NON-INVERT 5.5V SC88	NC7WZ07P6	U47	SC70-6	NC7WZ07P6
124	2	IC	IC FLASH 512MBIT SPI/QUAD 8WSON	IS25WP512M-JLLA3	U48,U49	WSON-8	IS25WP512M-JLLA3
125	1	IC	GE PHY 1PORT 10/100/1000Mb/s 2.97V~3.63V 40-QFN(5x5mm)	RTL8211FDI	U50	QFN40	RTL8211FDI-CG
126	1	IC	IC GATE AND 2CH 4-INP 14TSSOP	SN74HCS21QPWRQ	U52	TSSOP14	SN74HCS21QPWRQ1
127	1	IC	IC SUPERVISOR 1 CHANNEL 4X2SON	TPS3831G18DQN	U53	X2SON4	TPS3831G18DQNR
128	1	IC	IC BUS SWITCH 2 X 1.4 16TSSOP	TCA9546A	U54	TSSOP16	TCA9546APWR
129	1	IC	IC RTC CLOCK/CALENDAR I2C 8SO	PCF8523T	U55	SO8	PCF8523T/1,118
130	1	IC	SENSOR DIGITAL -40C-125C 10DFN	EMC1413-A-AIA-TR	U56	QFN10	EMC1413-A-AIA-TR
131	1	IC	IC USB TO UART/MPSSE QUAD 56VQFN	FT4232H-56Q-REEL	U57	VQFN-56	FT4232H-56Q-REEL
132	1	IC	IC EEPROM 2KBIT MIC WIRE SOT23-6	93LC56BT-I/OT	U58	SOT23-6	93LC56BT-I/OT
133	1	IC	IC BUF 1bit NON-INVERT 1.65V to 5.5V SOT23-5	SN74LVC1G17	U59	SOT23-5	SN74LVC1G17DBVR
134	1	VR	TRIMMER 25K OHM 0.25W GW TOP ADJ	3314G-1-253E	VR1	3314G-1	3314G-1-253E
135	1	OSC	CRYSTAL 32.7680KHZ 9PF SMD	32.768KHZ	Y1	3_2mmX1_5mm	FC-135R 32.7680KF-AC3
136	1	CRYSTAL	Automotive & Industrial Grade Ceramic Base SMD Crystal	12MHz	Y2	CRY3225	ABM8AIG-12.000MHZ-12-D2Z-T